

# DriftTrak® Headed Stud

Slab Integrated Bypass

### Description

DriftTrak® Headed Stud saves the time and expense of installing DriftTrak after the concrete slab has been poured, by integrating it directly into the slab before pouring. The headed studs come preinstalled to the DriftTrak and function as the attachment to the post-tensioned slab instead of welding to the pour stop angle or use of PAF's or anchors. Once concrete is poured, the DriftTrak is ready to support exterior steel framing using any DriftTrak Bypass clip (DTSLB-HD or DTLB-HD) to accommodate vertical deflection and lateral drift requirements or provide a rigid attachment to the floor slab.



US Patent #7,503,150 & Patent Pending

### Material Composition

**Track Material:** ASTM A1003/A1003M Structural Grade 50 (340) Type H, ST50H (ST340H): 50ksi (340MPa) minimum yield strength, 65ksi (450MPa) minimum tensile strength, 97mil minimum thickness (12 gauge, 0.1017" design thickness) with ASTM A653/A653M G60 (Z180) hot dipped galvanized coating.

**Headed Stud Material:** ASTM A29/A108, Grades 1010 through 1020 or equivalent, 45ksi (310MPa) minimum yield strength, 55ksi (380MPa) minimum tensile strength, 3/8" diam. x 3 1/8" length with 3/4" head diameter.

**Clip Material:** *DriftTrak – Headed Stud can be used with DTSLB-HD and DTLB-HD clips:* ASTM A1003/A1003M Structural Grade 50 (340) Type H, ST50H (ST340H): 50ksi (340MPa) minimum yield strength, 65ksi (450MPa) minimum tensile strength, 97mil minimum thickness (12 gauge, 0.1017" design thickness) with ASTM A653/A653M G90 (Z275) hot dipped galvanized coating.

### DriftTrak Headed Stud Allowable Loads

DriftTrak® Headed Studs with DTSLB-HD, Recommended Allowable Load (lbs): F2											
DriftTrak® Headed Studs with DTLB-HD, Recommended Allowable Load (lbs): F2 & F3											
Screw Patterns with #12 Screws	F2 Load Direction						F3 Load Direction				
	DTSLB362/400-HD	DTSLB600-HD & DTSLB800-HD <i>Offset = 1.25" max</i>		DTLB362/400-HD	DTLB600-HD & DTLB800-HD		DTLB362/400-HD <i>Offset = 1" max</i>	DTLB600-HD <i>Offset = 1" max</i>		DTLB800-HD <i>Offset = 1" max</i>	
	2 Screws	2 Screws	3 Screws	4 Screws	4 Screws	6 Screws	4 Screws	4 Screws	6 Screws	4 Screws	6 Screws
33mil (20ga), 33ksi stud	376	376	564	752	752	1,128	227	258	308	226	263
33mil (20ga), 50ksi stud	544	544	816	1,088	1,088	1,632	329	373	446	326	381
43mil (18ga), 33ksi stud	560	560	840	1,120	1,120	1,657	339	384	459	336	392
43mil (18ga), 50ksi stud	810	810	1,215	1,620	1,620	1,657	490	555	664	486	567
54mil (16ga), 33ksi stud	788	788	1,182	1,576	1,576	1,657	477	540	646	473	552
54mil (16ga), 50ksi stud	1,138	1,138	1,657	1,657	1,657	1,657	688	780	933	683	797
68mil (14ga), 50ksi stud	1,554	1,554	1,657	1,657	1,657	1,657	940	1,064	1,274	932	1,088
97mil (12ga), 50ksi stud	1,554	1,554	1,657	1,657	1,657	1,657	940	1,064	1,274	932	1,088
<b>Max Allowable Clip Load</b>	<b>1,657</b>	<b>1,657</b>		<b>1,657</b>	<b>1,657</b>		<b>1,163</b>	<b>1,908</b>		<b>1,272</b>	

### Notes:

- Clips are manufactured to fit into the DriftTrak PTS and provide a rigid/slip connection to the stud and allow free lateral movement of the structure.
- Design loads are for attachment of DriftTrak to stud and DriftTrak itself. Load tables reflect horizontal loads (F2) and vertical loads (F3).
- Loads listed reflect force in a single direction. When multiple loads react on the connection, it is the responsibility of the designer to check the interaction of forces.
- Allowable load tables incorporate eccentric loading of fasteners.
- Torsional effects are considered on screw group for F3 allowable loads. It is assumed that all of the torsional moment is taken by the connection to the stud.
- Allowable loads have not been increased for wind, seismic, or other factors.
- Maximum tension on a single anchor should not exceed 1,600 lbs ASD. In tension and shear, the strength of the anchor itself should be considered. The weld does not need to be considered in tension or shear as the load table and 1,600 lb ASD tension maximum are inclusive of the strength of the welds.
- Designers must check headed stud tension and shear anchorage capacity in concrete per ACI 318 based on actual headed stud edge distance and concrete compressive strength. For more information, call TSN Technical Support.
- One row of bridging is recommended at a maximum distance of 18" from DriftTrak if no other stud lateral restraint is present.
- Offset is measured from the open face of the track (slab edge) to the inside face of the stud.

### Load Direction

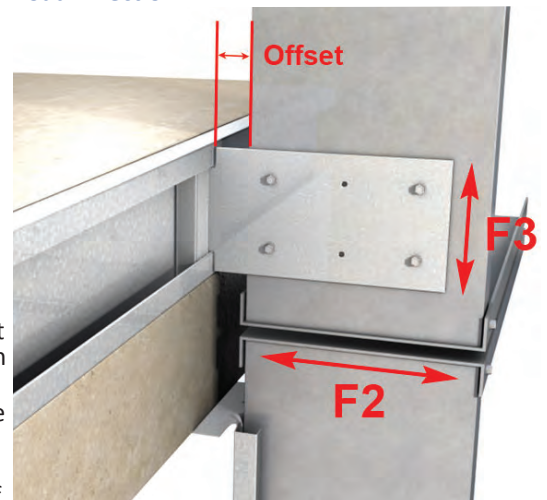

**Nomenclature**

DriftTrak® Headed Stud comes in 10' or 12' lengths, with headed studs in a single, centered row (See drawing on next page). To specify DriftTrak, list "DTH," followed by the length.

**Example:** 12 ft. length  
**Designate:** DriftTrak® DTH – 12ft.

**DriftTrak® Headed Stud: Dimensions, Layout and Stud Spacing**

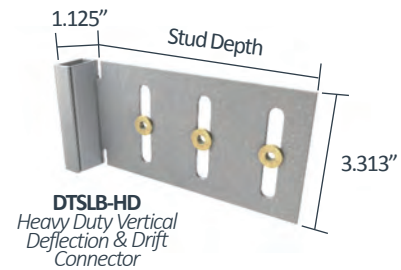
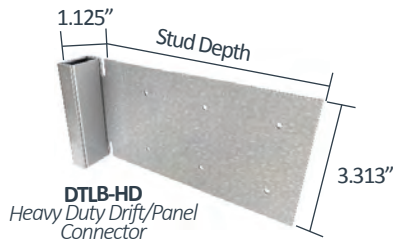
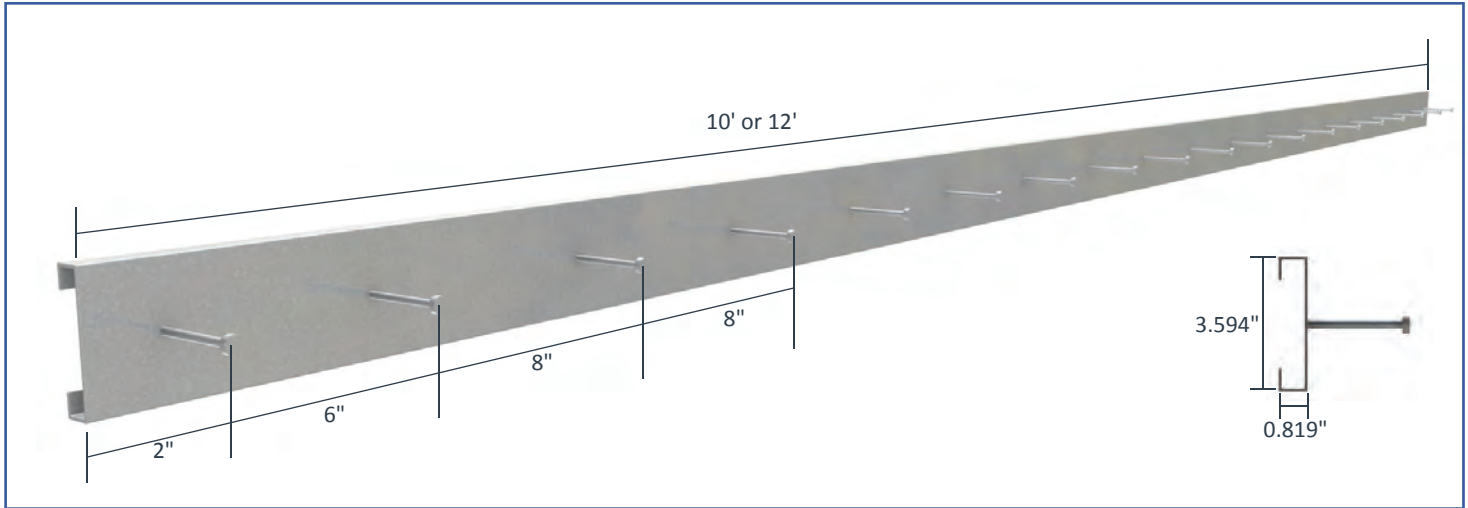

**Fastener Patterns**

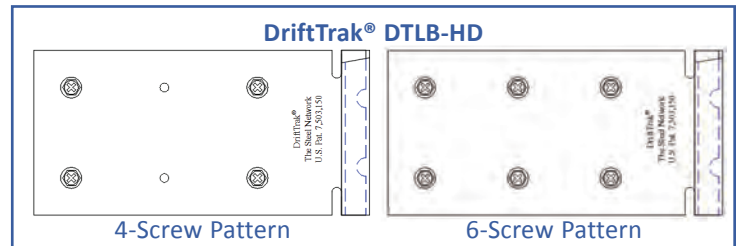
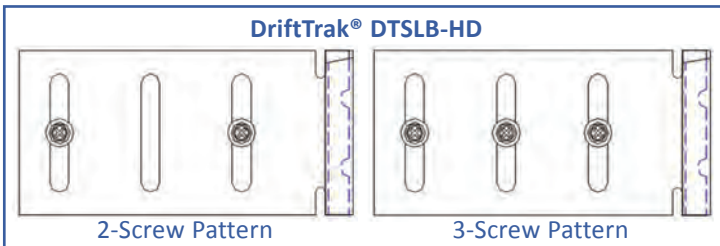

**Example Details**

