

Design of Cold-Formed Steel Built-Up Post Members

Technical Note

Design of Cold-Formed Steel
Built-Up Post Members

By: Muhammad Ghoraba
Nabil Rahman, Ph.D, P.E.



The Steel Network, Inc.
2012-A T.W. Alexander Drive
P.O. Box 13887
Durham, NC 27709
Phone: (888)474-4876
www.steelnetwork.com

DESIGN OF COLD-FORMED STEEL BUILT-UP POST MEMBERS

Muhammad Ghoraba
Nabil A. Rahman, Ph.D., P.E.

INTRODUCTION

Cold-formed steel members made of built-up stud sections to support high gravity loads are needed in several situation in load bearing wall applications. This includes jamb members for framing around window and door openings, and posts for framing at corridors (Figure 1). The purpose of this technical note is to illustrate the flexural and torsional buckling design calculations of built-up post members composed of multiple stud sections facing one direction, and subjected to axial compression loads.

An axially compressed built-up stud member can buckle in one, or a combination, of the following modes: local buckling, distortional buckling, or global buckling. Both local and distortional buckling are localized modes of the elements making up the cross-section of the individual studs. Global buckling can occur in one of three modes: flexural buckling, torsional buckling, or flexural-torsional buckling. Section B1.7 of AISI S211-07 Standard “*North American Standard for Cold-Formed Steel Framing–Wall Stud Design*” provides guidance for the calculations of the design strength of built-up stud members. The standard references Section D1.2 of AISI S100-07 “*North American Specification for the Design of Cold-Formed Steel Structural Members*”, which shows that the spacing between fasteners connecting the individual studs together affects the nominal global buckling stress of the built-up member. If the fastener spacing does not satisfy the stated condition in Section D1.2, the global buckling stress of the built-up member should be calculated based on the section properties of the individual stud members.



Figure 1: Built-up Post Members

DESIGN REQUIREMENTS

Section D1.2 of the AISI S100-07 states that:

“For compression members composed of two sections in contact, the available axial strength [factored axial resistance] shall be determined in accordance with Section C4.1(a) subject to the following modification. If the buckling mode involves relative deformations that produce shear forces in the connectors between individual shapes, KL/r is replaced by $(KL/r)_m$ calculated as follows:

$$\left(\frac{KL}{r}\right)_m = \sqrt{\left(\frac{KL}{r}\right)_o^2 + \left(\frac{a}{r_i}\right)^2}$$

Where:

$(KL/r)_o$ = Overall slenderness ratio of entire section about built-up member axis.

a = Intermediate fastener or spot weld spacing.

r_i = Minimum radius of gyration of full-unreduced cross-sectional area of an individual shape in a built-up member.

In addition, the fastener strength [resistance] and spacing shall satisfy the following:

- (1) The intermediate fastener or spot weld spacing, a, is limited such that (a/r_i) does not exceed one-half the governing slenderness ratio of the member.”

The application of the AISI provisions in this section can be summarized as follows:

- (a) Compliance with condition 1 for the ratio (a/r_i) means that the built-up member acts together as one unit between lateral bracing points. Non-compliance with the condition means that individual stud sections of the built-up member act individually between lateral bracing points.
- (b) If the ratio (a/r_i) satisfies condition 1, the modified overall section slenderness ratio is to be calculated using the full section properties of the built-up member. The torsional buckling stress (σ_t) should be calculated twice; once using the full section properties of the built-up member between lateral bracing points, and once using single stud section properties between fastener locations. The elastic flexural torsional buckling stress (F_{et}) should be calculated for each case and the lower value would govern.
- (c) If the ratio (a/r_i) does not satisfy condition 1, the modified overall section slenderness ratio should be checked against the slenderness ratio of a single stud section between lateral bracing points. The larger slenderness ratio would govern. The torsional buckling stress (σ_t) should be calculated using single stud section properties between lateral bracing points.

DESIGN EXAMPLES

Example (1)

Calculate the axial compressive strength of a built-up post composed of 4 standard stud sections 600S200-97 (50 ksi) given:

- Post height = 10.54 ft
- No intermediate lateral bracing
- Fastener spacing (a) = 18 in. o.c.
- Nominal axial compressive strength of post for distortional buckling limit state (P_{n-DB}) is 171.0 kips.

Solution

The 600S200-97 (50 ksi) section dimensions of the individual stud are given below:

Dimension	Definition	Value (in.)
D	Overall section depth	6.0
B	Flange width	2.0
d _l	Width of return lip	0.625
R	Inside bend radius	0.1525
t	Design thickness	0.1017
d ₀	Depth of the standard punch-out	1.5
d	Flat width of the web	5.4916
b	Flat width of flange	1.4916
d _{lf}	Flat width of the return lip	0.3708

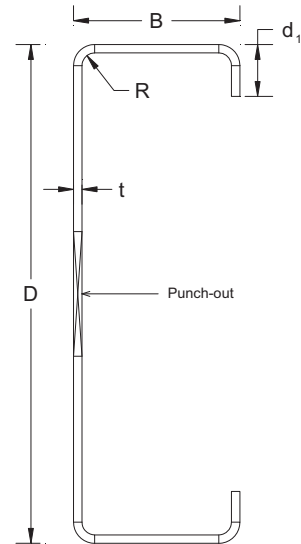

(a) Global Buckling Stress Calculation

$$\frac{K_x L_x}{r_x} = \text{slenderness ratio about the centroidal X-axis}$$

$$= \frac{10.54 * 12}{2.293} = 55.15$$

\bar{X} = horizontal distance from the centroid of the full post section to the back of the web of the stud in the most left (Figure 2)
= 3.57 in.

I_{yp} = total moment of inertia of the post section about the centroidal Y-axis
= 23.465 in.⁴

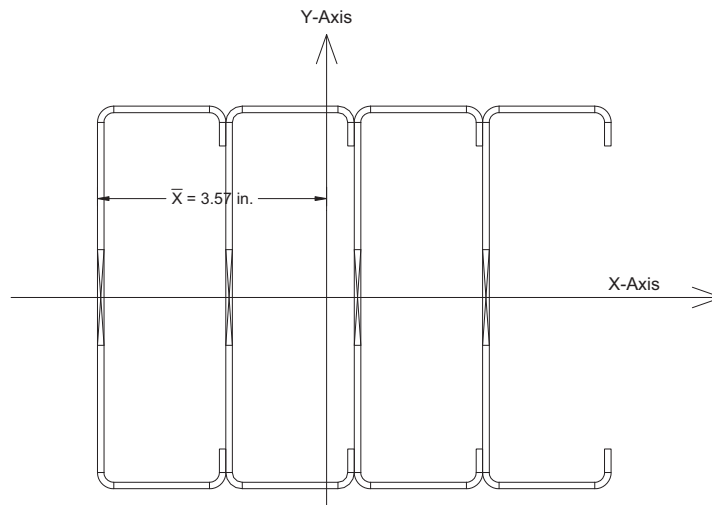

Figure 2: Location of Centroidal Axes for Post

$$A_{gp} = \text{total gross area of the post section} \\ = A_g * (\text{number of sections}) \\ = 1.067 * 4 = 4.269 \text{ in.}^2$$

$$r_{yp} = \text{radius of gyration of the post section about the centroidal Y-axis} \\ = \sqrt{\frac{I_{yp}}{A_{gp}}} = \sqrt{\frac{23.465}{4.269}} = 2.345 \text{ in.}$$

$$\frac{a}{r_i} = \frac{\text{fastener spacing}}{\text{minimum radius of gyration of individual shape}} \\ = \frac{18}{0.705} = 25.53$$

$$\left(\frac{K_y L_y}{r_y}\right)_m = \text{overall slenderness ratio of entire post section about built-up member axis (Y-axis)}$$

$$= \sqrt{\left(\frac{K_y L_y}{r_{yp}}\right)^2 + \left(\frac{a}{r_i}\right)^2} \quad (\text{Equation D1.2-1}) \\ = \sqrt{\left(\frac{10.54 * 12}{2.345}\right)^2 + (25.53)^2} = 59.68$$

$$\left(\frac{KL}{r}\right)_{\max} = \text{maximum of } \left[\frac{K_x L_x}{r_x}, \left(\frac{K_y L_y}{r_y}\right)_m\right] \\ = 59.68$$

$$\text{Since } \left(\frac{a}{r_i} = 25.53\right) < \left[0.5 \left(\frac{KL}{r}\right)_{\max} = 29.84\right] \rightarrow \text{Condition 1 in Section D1.2 is satisfied.}$$

$$F_{ef} = \text{elastic flexural buckling stress} \\ = \frac{\pi^2 E}{\left(\frac{KL}{r}\right)_{\max}^2} \quad (\text{Equation C4.1.1-1}) \\ = \frac{\pi^2 * 29500}{(59.68)^2} = 81.74 \text{ ksi}$$

$$\sigma_{ex} = \frac{\pi^2 E}{\left(\frac{K_x L_x}{r_x}\right)^2} \quad (\text{Equation C3.1.2.1-11}) \\ = \frac{\pi^2 * 29500}{(55.15)^2} = 95.73 \text{ ksi}$$

The torsional buckling stress between lateral bracing points should be calculated using the full section properties of the post:

$$J_p = \text{Saint-Venant torsional constant for post section} \\ = J * (\text{number of sections}) \\ = (3.679 * 10^{-3}) * 4 = 1.472 * 10^{-2} \text{ in.}^4$$

$$C_{wp} = \text{warping constant for post section} \\ = C_w * (\text{number of sections})$$

$$\begin{aligned}
&= 4.08 * 4 = 16.32 \text{ in.}^6 \\
x_{op} &= \text{distance from shear center to centroid of the post section} \\
&= 0 \text{ (Assuming that shear center coincides with the centroid of the post section)} \\
r_{op} &= \text{polar radius of gyration of post section about the shear center} \\
&= \sqrt{(r_x)^2 + (r_{yp})^2 + (x_{op})^2} \quad \text{(Equation C3.1.2.1-7)} \\
&= \sqrt{(2.293)^2 + (2.345)^2} = 3.28 \text{ in.}
\end{aligned}$$

$$\begin{aligned}
\sigma_{t(1)} &= \text{torsional buckling stress between lateral bracing points} \\
&= \frac{1}{A_{gp} r_{op}^2} \left[GJ_p + \frac{\pi^2 EC_{wp}}{(K_t L_t)^2} \right] \quad \text{(Equation C3.1.2.1-9)} \\
&= \frac{1}{4.269 * (3.28)^2} * \left[11300 * (1.472 * 10^{-2}) + \frac{\pi^2 * 29500 * 16.32}{(10.54 * 12)^2} \right] \\
&= 10.09 \text{ ksi}
\end{aligned}$$

$$\begin{aligned}
\beta_1 &= 1 - (x_{op}/r_{op})^2 \quad \text{(Equation C4.1.2-3)} \\
&= 1 - (0/3.28)^2 = 1
\end{aligned}$$

$$\begin{aligned}
F_{et(1)} &= \text{elastic torsional or flexural-torsional buckling stress between lateral bracing points} \\
&= \frac{1}{2\beta_1} \left[(\sigma_{ex} + \sigma_{t(1)}) - \sqrt{(\sigma_{ex} + \sigma_{t(1)})^2 - 4\beta_1 \sigma_{ex} \sigma_{t(1)}} \right] \quad \text{(Equation C4.1.2-1)} \\
&= \sigma_{t(1)} \text{ since } (\beta_1 = 1) = 10.09 \text{ ksi}
\end{aligned}$$

The torsional buckling stress between fasteners should be calculated using the section properties of an individual stud:

$$\begin{aligned}
\sigma_{t(2)} &= \text{torsional buckling stress between fasteners} \\
&= \frac{1}{A_g r_o^2} \left[GJ + \frac{\pi^2 EC_w}{(a)^2} \right] \quad \text{(Equation C3.1.2.1-9)} \\
&= \frac{1}{1.067 * (2.767)^2} * \left[11300 * (3.679 * 10^{-3}) + \frac{\pi^2 * 29500 * 4.08}{(18)^2} \right] \\
&= 453.84 \text{ ksi}
\end{aligned}$$

$$\begin{aligned}
\beta_2 &= 1 - (x_o/r_o)^2 \quad \text{(Equation C4.1.2-3)} \\
&= 1 - (-1.378/2.767)^2 = 0.752
\end{aligned}$$

$$\begin{aligned}
F_{et(2)} &= \text{elastic torsional or flexural-torsional buckling stress between fasteners} \\
&= \frac{1}{2\beta_2} \left[(\sigma_{ex} + \sigma_{t(2)}) - \sqrt{(\sigma_{ex} + \sigma_{t(2)})^2 - 4\beta_2 \sigma_{ex} \sigma_{t(2)}} \right] \quad \text{(Equation C4.1.2-1)} \\
&= \frac{1}{2 * 0.752} \left[(95.73 + 453.84) - \sqrt{(95.73 + 453.84)^2 - 4 * 0.752 * 95.73 * 453.84} \right] \\
&= 90.18 \text{ ksi}
\end{aligned}$$

$$\begin{aligned}
F_{et} &= \text{elastic torsional or flexural-torsional buckling stress} \\
&= \min. \text{ of } (F_{et(1)}, F_{et(2)}) = 10.09 \text{ ksi} < (F_{ef} = 81.74 \text{ ksi})
\end{aligned}$$

∴ F_e = elastic buckling stress

= 10.09 ksi (controlled by torsion)

$$\lambda_c = \sqrt{\frac{F_y}{F_e}} \quad \text{(Equation C4.1-4)}$$

$$= \sqrt{\frac{50}{10.09}} = 2.226 > 1.5 \text{ (elastic buckling)}$$

F_n = nominal global buckling stress

$$= \left(\frac{0.877}{\lambda_c^2} \right) F_y \quad \text{(Equation C4.1-3)}$$

$$= \left(\frac{0.877}{(2.226)^2} \right) * 50 = 8.85 \text{ ksi}$$

(b) Effective Area Calculation

The effective area of the full built-up member section can be calculated using Section B of AISI S100-07 as the sum of the effective areas of individual stud sections, with a compression stress equals $F_n = 8.85$ ksi. Detailed calculations are not included here:

A_e = effective area of individual sections
= 0.915 in.²

A_{ep} = total effective area of built-up post member
= A_e x (number of sections)
= 0.915 * 4 = 3.66 in.²

(c) Available Axial Compressive Strength

P_{n-GB} = nominal axial compressive strength of post section for global buckling
= $A_{ep} F_n$ (Equation C4.1-1)
= 3.66 * 8.85 = 32.39 kips < ($P_{n-DB} = 171$ kips)

∴ $P_n = \underline{32.39 \text{ kips}}$

P_{all} = allowable axial compressive strength of post member
= P_n / Ω_c
= 32.39/1.8 = 18.0 kips

P_d = design axial compressive strength of post member
= $\phi_c P_n$
= 0.85 * 32.39 = 27.5 kips

Example (2)

Calculate the axial compressive strength of a built-up post composed of 4 SigmaStud[®] stud sections 600SG250-68 (50 ksi) given:

- Post height = 10.54 ft
- No intermediate lateral bracing
- Fastener spacing (a) = 18 in. o.c.
- Nominal axial compressive strength of post for distortional buckling limit state (P_{n-DB}) is 140.0 kips.

Solution

The 600SG250-68 (50 ksi) section dimensions of the individual stud are given below:

Dimension	Definition	Value (in.)
D	Overall section depth	6.0
B	Flange width	2.5
A	Web flat	1.25
C	Web return	1
E _o	Web return	0.625
d ₁	Width of return lip 1	0.6626
d ₂	Width of return lip 2	0.5
R	Inside bend radius	0.105
t	Design thickness	0.0713
r	R + t/2	0.14065
u ₁	rπ/2	0.2209
d ₀	Depth of the standard punch-out	1.5
d _{1f}	Flat width of the return lip 1	0.31
d _{2f}	Flat width of the return lip 2	0.3237
b	Flat width of the flange	2.1474
L ₃	Flat width of the external web	0.9957
L ₂	Flat width of the inclined web	1.0233
L ₁	Flat width of the internal web	2.094

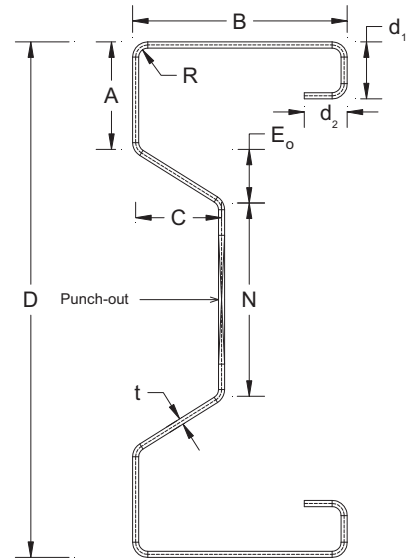

(a) Global Buckling Stress Calculation

$$\frac{K_x L_x}{r_x} = \text{slenderness ratio about the centroidal X-axis}$$

$$= \frac{10.54 * 12}{2.32} = 54.53$$

$$\bar{X} = \text{horizontal distance from the centroid of the post section to the back of the web of the stud in the most left (Figure 3)}$$

$$= 4.79 \text{ in.}$$

$$I_{yp} = \text{total moment of inertia of the post section about the centroidal Y-axis}$$

$$= 32.82 \text{ in.}^4$$

$$A_{gp} = \text{total gross area of the post section}$$

$$= A_g * (\text{number of sections})$$

$$= 0.969 * 4 = 3.875 \text{ in.}^2$$

$$r_{yp} = \text{radius of gyration of the post section about the centroidal Y-axis}$$

$$= \sqrt{\frac{I_{yp}}{A_{gp}}} = \sqrt{\frac{32.82}{3.875}} = 2.91 \text{ in.}$$

$$\frac{a}{r_i} = \frac{\text{fastener spacing}}{\text{minimum radius of gyration of individual shape}}$$

$$= \frac{18}{0.81} = 22.22$$

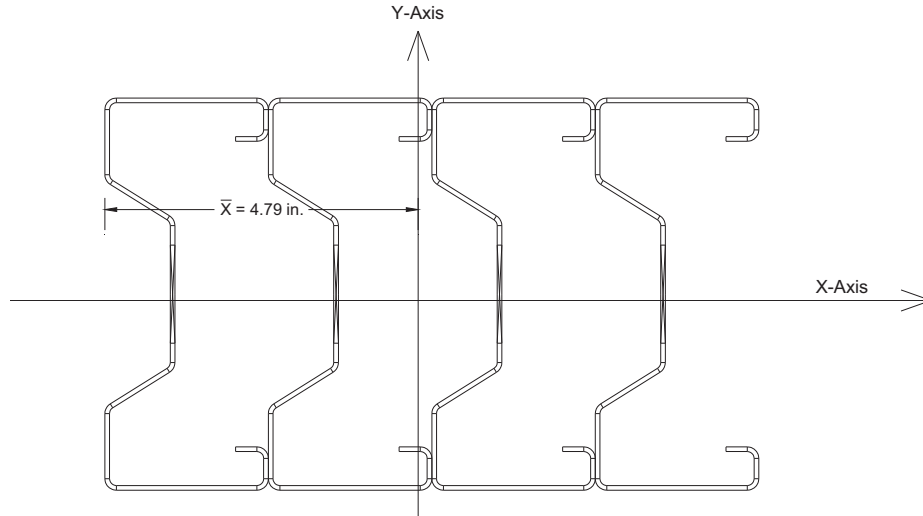

Figure 3: Location of Centroidal Axes for Post

$\left(\frac{K_y L_y}{r_y}\right)_m$ = overall slenderness ratio of entire post section about built-up member axis (Y-axis)

$$= \sqrt{\left(\frac{K_y L_y}{r_{yp}}\right)^2 + \left(\frac{a}{r_i}\right)^2} \quad \text{(Equation D1.2-1)}$$

$$= \sqrt{\left(\frac{10.54 * 12}{2.91}\right)^2 + (22.22)^2} = 48.81$$

$$\left(\frac{KL}{r}\right)_{\max} = \text{maximum of } \left[\frac{K_x L_x}{r_x}, \left(\frac{K_y L_y}{r_y}\right)_m \right]$$

$$= 54.53$$

Since $\left(\frac{a}{r_i} = 22.22\right) < \left[0.5\left(\frac{KL}{r}\right)_{\max} = 27.26\right] \rightarrow$ Condition 1 in Section D1.2 is satisfied.

F_{ef} = elastic flexural buckling stress

$$= \frac{\pi^2 E}{\left(KL/r\right)_{\max}^2} \quad \text{(Equation C4.1.1-1)}$$

$$= \frac{\pi^2 * 29500}{(54.53)^2} = 97.93 \text{ ksi}$$

$$\sigma_{ex} = \frac{\pi^2 E}{\left(K_x L_x / r_x\right)^2} \quad \text{(Equation C3.1.2.1-11)}$$

$$= \frac{\pi^2 * 29500}{(54.53)^2} = 97.93 \text{ ksi}$$

The torsional buckling stress between lateral bracing points should be calculated using the full section properties of the post.

J_p = Saint-Venant torsional constant for post section

$$= J * (\text{number of sections})$$

$$= 0.00164 * 4 = 0.00657 \text{ in.}^4$$

C_{wp} = warping constant for post section

$$= C_w * (\text{number of sections})$$

$$= 7.145 * 4 = 28.58 \text{ in.}^6$$

x_{op} = distance from shear center to centroid of the post section

$$= 0 \text{ (Assuming that shear center coincides with the centroid of the post section)}$$

r_{op} = polar radius of gyration of post section about the shear center

$$= \sqrt{(r_x)^2 + (r_{yp})^2 + (x_{op})^2} \quad (\text{Equation C3.1.2.1-7})$$

$$= \sqrt{(2.32)^2 + (2.91)^2} = 3.72 \text{ in.}$$

$\sigma_{t(1)}$ = torsional buckling stress between lateral bracing points

$$= \frac{1}{A_{gp} r_{op}^2} \left[GJ_p + \frac{\pi^2 EC_{wp}}{(K_t L_t)^2} \right] \quad (\text{Equation C3.1.2.1-9})$$

$$= \frac{1}{3.875 * (3.72)^2} * \left[11300 * 0.00657 + \frac{\pi^2 * 29500 * 28.58}{(10.54 * 12)^2} \right]$$

$$= 11.07 \text{ ksi}$$

$\beta_1 = 1 - (x_{op}/r_{op})^2$ (Equation C4.1.2-3)

$$= 1 - (0/3.72)^2 = 1$$

$F_{et(1)}$ = elastic torsional or flexural-torsional buckling stress between lateral bracing points

$$= \frac{1}{2\beta_1} \left[(\sigma_{ex} + \sigma_{t(1)}) - \sqrt{(\sigma_{ex} + \sigma_{t(1)})^2 - 4\beta_1 \sigma_{ex} \sigma_{t(1)}} \right] \quad (\text{Equation C4.1.2-1})$$

$$= \sigma_{t(1)} \text{ since } (\beta_1 = 1) = 11.07 \text{ ksi}$$

The torsional buckling stress between fasteners should be calculated using the section properties of an individual stud.

$\sigma_{t(2)}$ = torsional buckling stress between fasteners

$$= \frac{1}{A_g r_o^2} \left[GJ + \frac{\pi^2 EC_w}{(a)^2} \right] \quad (\text{Equation C3.1.2.1-9})$$

$$= \frac{1}{0.969 * (2.715)^2} * \left[11300 * 0.00164 + \frac{\pi^2 * 29500 * 7.145}{(18)^2} \right]$$

$$= 901.75 \text{ ksi}$$

$\beta_2 = 1 - (x_o/r_o)^2$ (Equation C4.1.2-3)

$$= 1 - (-1.155/2.715)^2 = 0.819$$

$$\begin{aligned}
F_{et(2)} &= \text{elastic torsional or flexural-torsional buckling stress between fasteners} \\
&= \frac{1}{2\beta_2} \left[(\sigma_{ex} + \sigma_{t(2)}) - \sqrt{(\sigma_{ex} + \sigma_{t(2)})^2 - 4\beta_2 \sigma_{ex} \sigma_{t(2)}} \right] \quad (\text{Equation C4.1.2-1}) \\
&= \frac{1}{2 * 0.819} \left[(97.93 + 901.75) - \sqrt{(97.93 + 901.75)^2 - 4 * 0.819 * 97.93 * 901.75} \right] \\
&= 95.87 \text{ ksi}
\end{aligned}$$

$$\begin{aligned}
F_{et} &= \text{elastic torsional or flexural-torsional buckling stress} \\
&= \min. \text{ of } (F_{et(1)}, F_{et(2)}) = 11.07 \text{ ksi} < (F_{ef} = 97.93 \text{ ksi})
\end{aligned}$$

$$\begin{aligned}
\therefore F_e &= \text{elastic buckling stress} \\
&= 11.07 \text{ ksi (controlled by torsion)}
\end{aligned}$$

$$\begin{aligned}
\lambda_c &= \sqrt{\frac{F_y}{F_e}} \quad (\text{Equation C4.1-4}) \\
&= \sqrt{\frac{50}{11.07}} = 2.125 > 1.5 \text{ (elastic buckling)}
\end{aligned}$$

$$\begin{aligned}
F_n &= \text{nominal global buckling stress} \\
&= \left(\frac{0.877}{\lambda_c^2} \right) F_y \quad (\text{Equation C4.1-3}) \\
&= \left(\frac{0.877}{(2.125)^2} \right) * 50 = 9.71 \text{ ksi}
\end{aligned}$$

(b) Effective Area Calculation

(c) The effective area of the full built-up member section can be calculated using Section B of AISI S100-07 as the sum of the effective areas of individual stud sections, with a compression stress equals $F_n = 9.71$ ksi. Detailed calculations are not included here. An assumption is made for the flanges of the Sigma sections to be considered as uniformly compressed elements with simple lip edge stiffeners, where the simple lip edge stiffener is equivalent to the L-shape edge stiffener formed by the return lips 1 and 2.

$$\begin{aligned}
A_e &= \text{effective area of individual sections} \\
&= 0.862 \text{ in.}^2
\end{aligned}$$

$$\begin{aligned}
A_{ep} &= \text{total effective area of built-up post member} \\
&= A_e \times (\text{number of sections}) \\
&= 0.862 * 4 = 3.448 \text{ in.}^2
\end{aligned}$$

(c) Available Axial Compressive Strength

$$\begin{aligned}
P_{n-GB} &= \text{nominal axial compressive strength of post section for global buckling} \\
&= A_{ep} F_n \quad (\text{Equation C4.1-1}) \\
&= 3.448 * 9.71 = 33.48 \text{ kips} < (P_{n-DB} = 140 \text{ kips})
\end{aligned}$$

$$\therefore P_n = \underline{33.48 \text{ kips}}$$

$$\begin{aligned}
P_{all} &= \text{allowable axial compressive strength of post member} \\
&= P_n / \Omega_c \\
&= 33.48 / 1.8 = \underline{18.6 \text{ kips}}
\end{aligned}$$

$$\begin{aligned}
P_d &= \text{design axial compressive strength of post member} \\
&= \phi_c P_n \\
&= 0.85 * 33.48 = \underline{28.5 \text{ kips}}
\end{aligned}$$

REFERENCES

AISI S100-07, “*North American Specification for the Design of Cold-Formed Steel Structural Members*”, American Iron and Steel Institute (AISI), 2007 Edition, Washington, DC.

AISI S211-07, “*North American Standard for Cold-Formed Steel Framing–Wall Stud Design*”, American Iron and Steel Institute (AISI), 2007 Edition, Washington, DC.

AISI S100-08, “*Cold-Formed Steel Design Manual*”, American Iron and Steel Institute (AISI), 2008 Edition, Washington, DC.

ASI SSS6, *Steel Smart System Version 6*, Cold Formed Steel Design Software, Applied Science International, LLC, Durham, NC.